



ST202

5V POWERED MULTI-CHANNEL RS-232 DRIVERS AND RECEIVERS

- SUPPLY VOLTAGE RANGE: 4.5 TO 5.5V
- SUPPLY CURRENT NO LOAD (TYP): 1.5mA
- TRANSMITTER OUTPUT VOLTAGE SWING (TYP): $\pm 9V$
- TRANSITION SLEW RATE (TYP.): 12V/ μs
- RECEIVER PROPAGATION DELAY (TYP.): 0.1 μs
- COMPATIBLE WITH MAX202
- RECEIVER INPUT VOLTAGE RANGE: $\pm 30V$
- DATA RATE (TYP.): 400Kbp/s
- OPERATING TEMPERATURE RANGE: -40 TO 85 °C, 0 TO 70°C

DESCRIPTION

The ST202 is a 2 driver, 2 receiver device following EIA/TIA-232 and V.28 communication standard. It is particularly suitable for applications where $\pm 12V$ is not available. The ST202 uses a single 5V power supply and only four external capacitors (0.1 μF). Typical applications are in: Portable Computers, Low Power Modems, Interfaces Translation, Battery Powered RS-232 Networks.

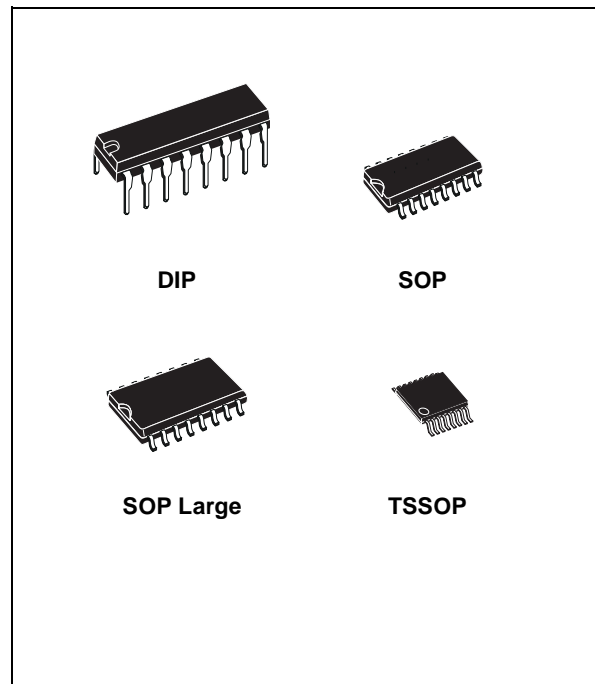

ORDERING CODES

Type	Temperature Range	Package	Comments
ST202CN	0 to 70 °C	DIP-16	25parts per tube / 40tube per box
ST202BN	-40 to 85 °C	DIP-16	25parts per tube / 40tube per box
ST202CD	0 to 70 °C	SO-16 (Tube)	50parts per tube / 20tube per box
ST202BD	-40 to 85 °C	SO-16 (Tube)	50parts per tube / 20tube per box
ST202CDR	0 to 70 °C	SO-16 (Tape & Reel)	2500 parts per reel
ST202BDR	-40 to 85 °C	SO-16 (Tape & Reel)	2500 parts per reel
ST202CW	0 to 70 °C	SO-16 Large (Tube)	49parts per tube / 25tube per box
ST202BW	-40 to 85 °C	SO-16 Large (Tube)	49parts per tube / 25tube per box
ST202CWR	0 to 70 °C	SO-16 Large (Tape & Reel)	1000 parts per reel
ST202BWR	-40 to 85 °C	SO-16 Large (Tape & Reel)	1000 parts per reel
ST202CTR	0 to 70 °C	TSSOP16 (Tape & Reel)	2500 parts per reel
ST202BTR	-40 to 85 °C	TSSOP16 (Tape & Reel)	2500 parts per reel

PIN CONFIGURATION

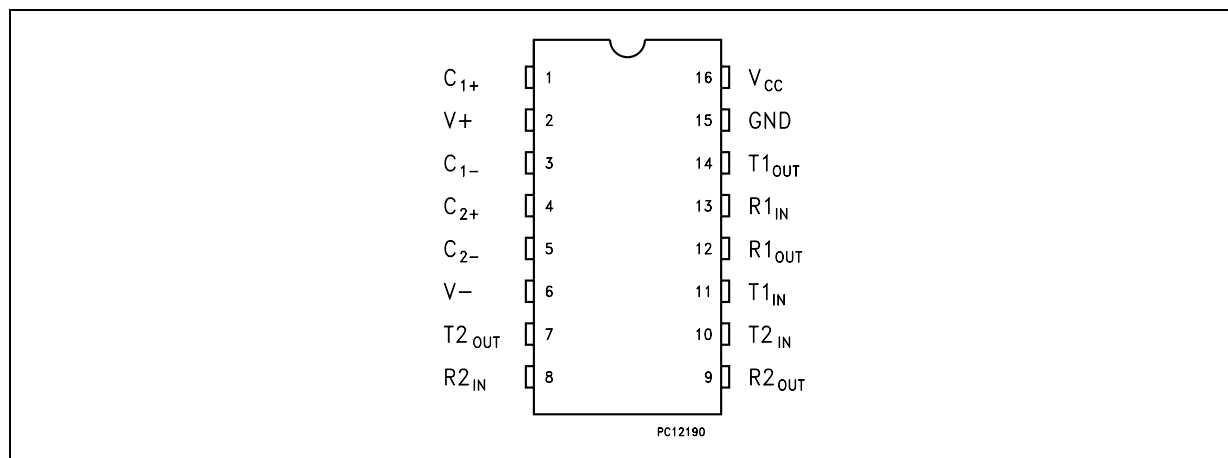

PIN DESCRIPTION

PIN N°	SYMBOL	NAME AND FUNCTION
1	C ₁₊	Positive Terminal for the first Charge Pump Capacitor
2	V+	Doubled Voltage Terminal
3	C ₁₋	Negative Terminal for the first Charge Pump Capacitor
4	C ₂₊	Positive Terminal for the second Charge Pump Capacitor
5	C ₂₋	Negative Terminal for the second Charge Pump Capacitor
6	V-	Inverted Voltage Terminal
7	T _{2OUT}	Second Transmitter Output Voltage
8	R _{2IN}	Second Receiver Input Voltage
9	R _{2OUT}	Second Receiver Output Voltage
10	T _{2IN}	Second Transmitter Input Voltage
11	T _{1IN}	First Transmitter Input Voltage
12	R _{1OUT}	First Receiver Output Voltage
13	R _{1IN}	First Receiver Input Voltage
14	T _{1OUT}	First Transmitter Output Voltage
15	GND	Ground
16	V _{CC}	Supply Voltage

ABSOLUTE MAXIMUM RATINGS

Symbol	Parameter	Value	Unit
V _{CC}	Supply Voltage	-0.3 to 6	V
V+	Extra Positive Voltage	(V _{CC} - 0.3) to 13.2	V
V-	Extra Negative Voltage	0.3 to -13.2	V
T _{IN}	Transmitter Input Voltage Range	-0.3 to (V _{CC} + 0.3)	V
R _{IN}	Receiver Input Voltage Range	± 30	V
T _{OUT}	Transmitter Output Voltage Range	± 15	V
R _{OUT}	Receiver Output Voltage Range	-0.3 to (V _{CC} + 0.3)	V
T _{SCTOUT}	Short Circuit Duration on T _{OUT}	infinite	

Absolute Maximum Ratings are those values beyond which damage to the device may occur. Functional operation under these condition is not implied.

ELECTRICAL CHARACTERISTICS

($C_1 - C_4 = 0.1\mu\text{F}$, $V_{CC} = 5\text{V} \pm 10\%$, $T_A = -40$ to 85°C , unless otherwise specified.
Typical values are referred to $T_A = 25^\circ\text{C}$)

Symbol	Parameter	Test Conditions	Min.	Typ.	Max.	Unit
I_{SUPPLY}	V_{CC} Power Supply Current	No Load		1.5	4	mA

TRANSMITTER ELECTRICAL CHARACTERISTICS

($C_1 - C_4 = 0.1\mu\text{F}$, $V_{CC} = 5\text{V} \pm 10\%$, $T_A = -40$ to 85°C , unless otherwise specified.
Typical values are referred to $T_A = 25^\circ\text{C}$)

Symbol	Parameter	Test Conditions	Min.	Typ.	Max.	Unit
V_{TOUT}	Output Voltage Swing	All Transmitter outputs are loaded with $3\text{K}\Omega$ to GND	± 5	± 9		V
I_{TIL}	Logic Pull-Up Current	$T_{\text{IN}} = 0\text{V}$		5	40	μA
V_{TIL}	Input Logic Threshold Low		0.8	1.4		V
V_{TIH}	Input Logic Threshold High			1.4	2	V
SR_{T}	Transition Slew Rate	$T_A = 25^\circ\text{C}$, $V_{CC} = 5\text{V}$ $R_L = 3$ to $7\text{K}\Omega$, $C_L = 50$ to 2500pF (Note 1)	6	12	30	$\text{V}/\mu\text{s}$
D_{R}	Data Rate	(Note 2)	200	400		Kbits/s
R_{TOUT}	Transmitter Output Resistance	$V_{CC} = V_+ = V_- = 0\text{V}$ $V_{\text{OUT}} = \pm 2\text{V}$	300			Ω
I_{SC}	Transmitter Output Short Circuit Current	one T_{XOUT} to GND	± 7	± 22		mA
t_{dT}	Propagation Delay Time	TTL-CMOS IN to RS-232 OUT $C_L = 150\text{pF}$ (50% to 50%)		1.3	3.5	μs

Note 1: Measured from 3V to -3V or from -3V to 3V.

Note 2: One transmitter output is loaded with $R_L = 3\text{K}\Omega$ to $7\text{K}\Omega$, $C_L = 50$ to 1000pF

RECEIVER ELECTRICAL CHARACTERISTICS

($C_1 - C_4 = 0.1\mu\text{F}$, $V_{CC} = 5\text{V} \pm 10\%$, $T_A = -40$ to 85°C , unless otherwise specified.
Typical values are referred to $T_A = 25^\circ\text{C}$)

Symbol	Parameter	Test Conditions	Min.	Typ.	Max.	Unit
V_{RIN}	Receiver Input Voltage Operating Range		-30		30	V
R_{RIN}	RS-232 Input Resistance	$T_A = 25^\circ\text{C}$	3	5	7	$\text{K}\Omega$
V_{RIL}	RS-232 Input Threshold Low		0.8	1.3		V
V_{RIH}	RS-232 Input Threshold High			1.8	2.4	V
V_{RIHYS}	RS-232 Input Hysteresis	$V_{CC} = 5\text{V}$	0.2	0.5	1	V
V_{ROL}	TTL/CMOS Output Voltage Low	$I_{\text{OUT}} = 3.2\text{mA}$ (to V_{CC})		0.2	0.4	V
V_{ROH}	TTL/CMOS Output Voltage High	$I_{\text{OUT}} = 1\text{mA}$ (to GND)	3.5	$V_{CC}-0.2$		V
I_{SCR}	Receiver Output Short Circuit Current	to GND to V_{CC}	2 10	10 30		mA mA
t_{dR}	Propagation Delay Time	$C_L = 150\text{pF}$ (Note 1)		0.1	0.5	μs

Note 1: RS-232 IN to TTL-CMOS OUT (from 50% to 50%)

APPLICATION CIRCUITS (note 1, note 2)

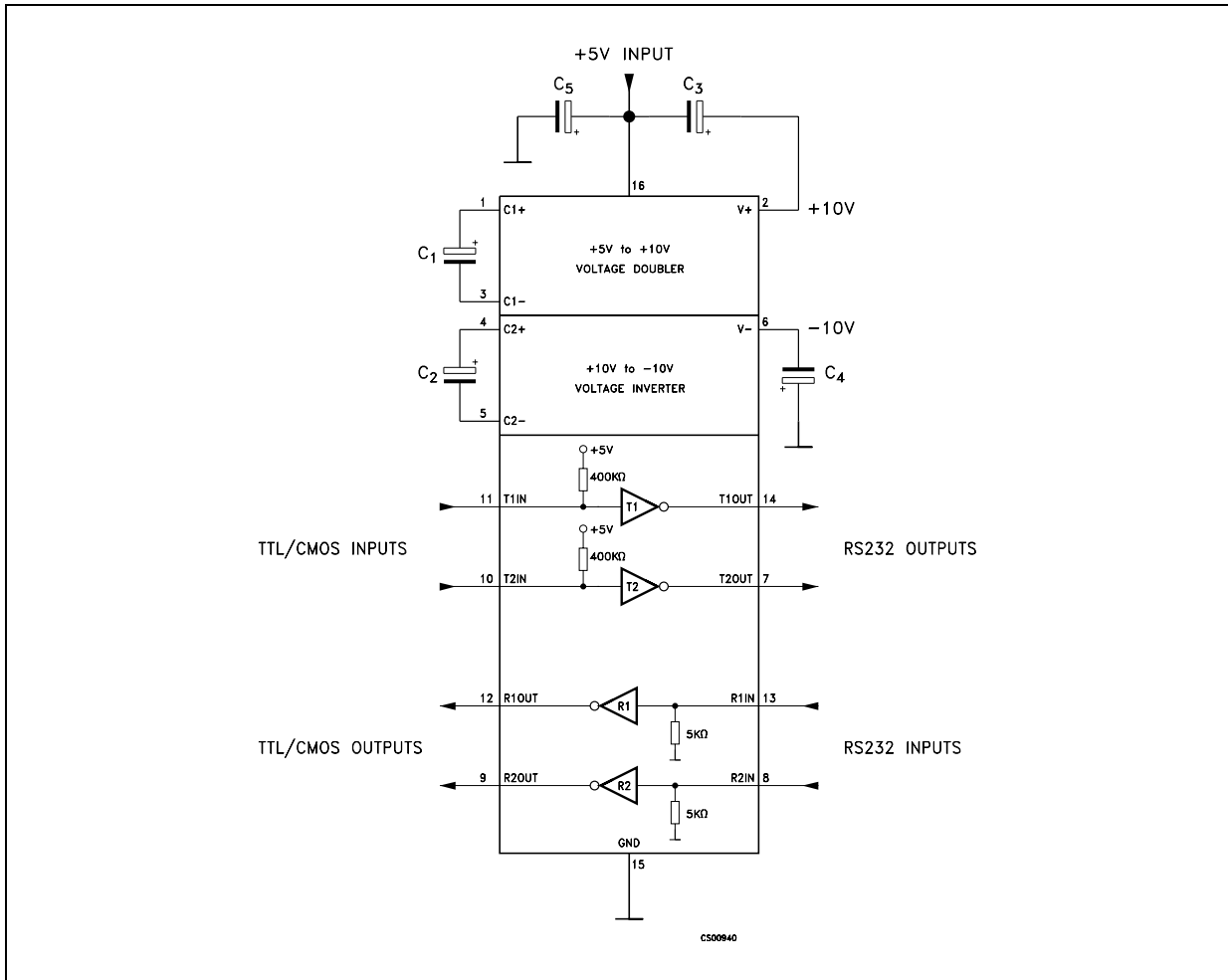

Note 1: C₁₋₄ capacitors can even be 1μF ones.
 Note 2: C₁₋₄ can be common or biased capacitors.

CAPACITANCE VALUE (μF)

C1	C2.	C3	C4	C5
0.1	0.1	0.1	0.1	0.1

TYPICAL PERFORMANCE CHARACTERISTICS (unless otherwise specified $T_j = 25^\circ\text{C}$)

Figure 1 : Driver Voltage Transfer Characteristics

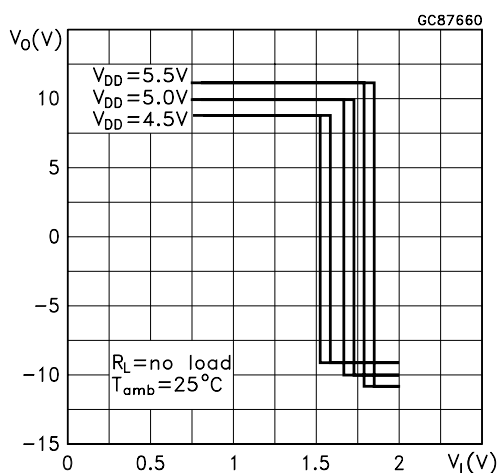

Figure 4 : Driver Output Capability Current vs Output Voltage

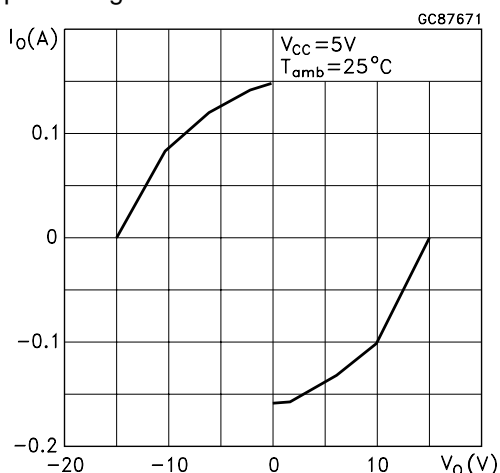

Figure 2 : Drive Short Circuit Output Current vs Temperature

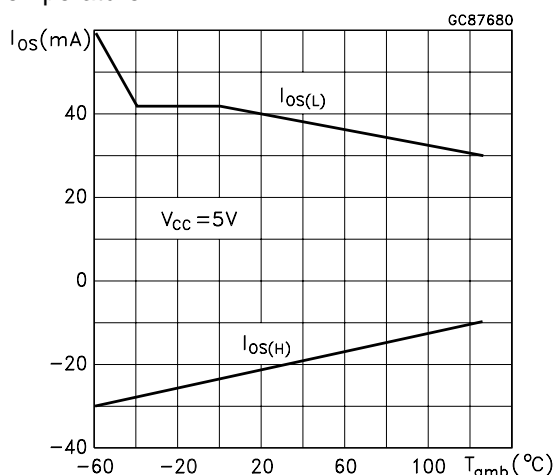

Figure 5 : Driver Short Circuit Supply Current vs Temperature

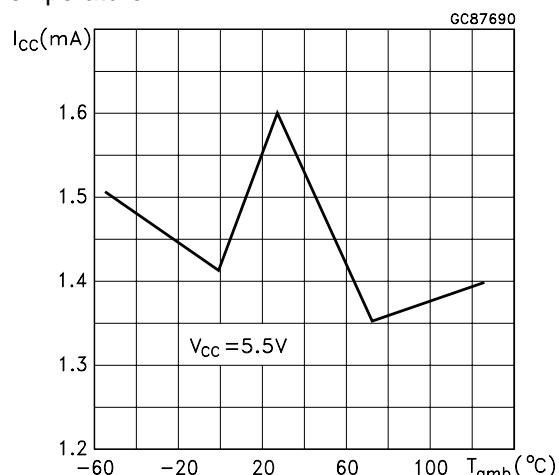

Figure 3 : Receiver Threshold vs Supply Voltage

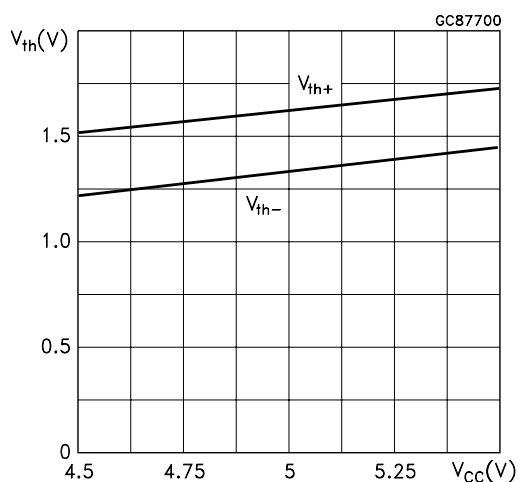
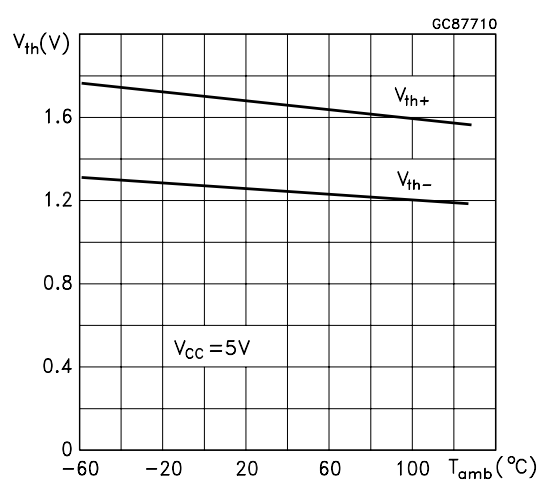
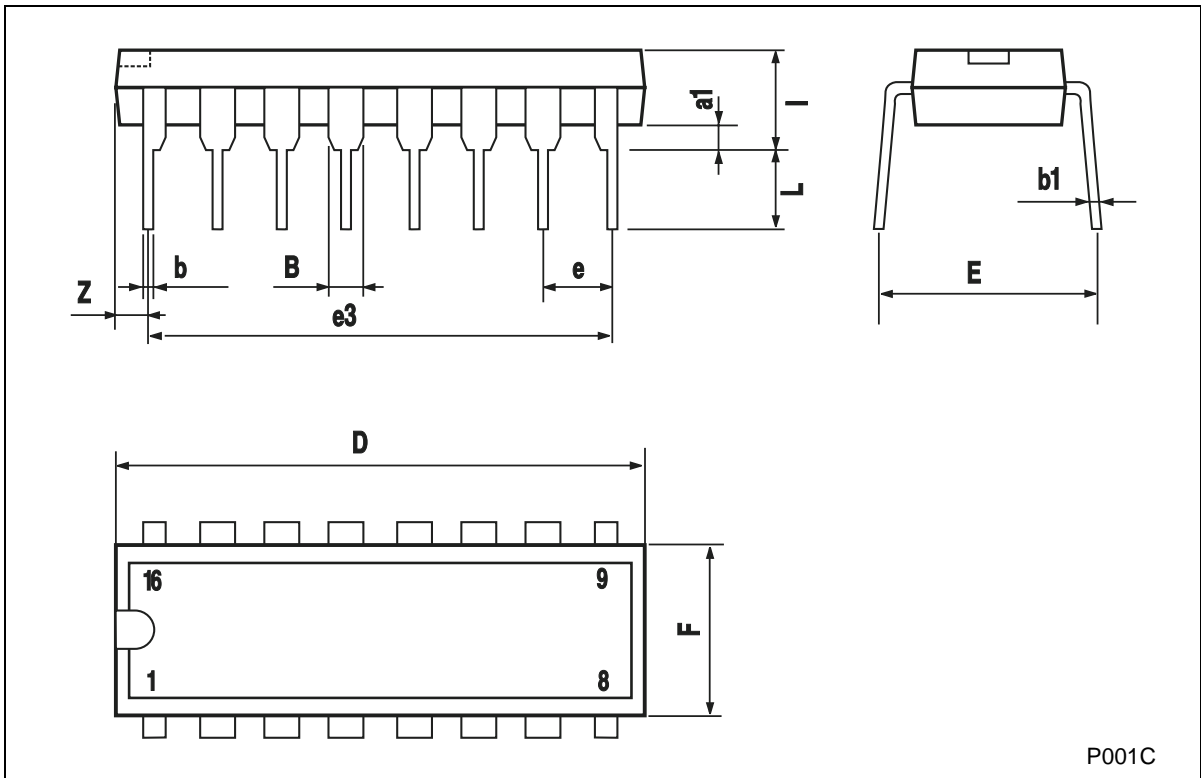

Figure 6 : Receiver Threshold vs Temperature



Plastic DIP-16 (0.25) MECHANICAL DATA

DIM.	mm.			inch		
	MIN.	TYP	MAX.	MIN.	TYP.	MAX.
a1	0.51			0.020		
B	0.77		1.65	0.030		0.065
b		0.5			0.020	
b1		0.25			0.010	
D			20			0.787
E		8.5			0.335	
e		2.54			0.100	
e3		17.78			0.700	
F			7.1			0.280
l			5.1			0.201
L		3.3			0.130	
Z			1.27			0.050



SO-16 MECHANICAL DATA

DIM.	mm.			inch		
	MIN.	TYP.	MAX.	MIN.	TYP.	MAX.
A			1.75			0.068
a1	0.1		0.2	0.003		0.007
a2			1.65			0.064
b	0.35		0.46	0.013		0.018
b1	0.19		0.25	0.007		0.010
C		0.5			0.019	
c1	45° (typ.)					
D	9.8		10	0.385		0.393
E	5.8		6.2	0.228		0.244
e		1.27			0.050	
e3		8.89			0.350	
F	3.8		4.0	0.149		0.157
G	4.6		5.3	0.181		0.208
L	0.5		1.27	0.019		0.050
M			0.62			0.024
S	8° (max.)					

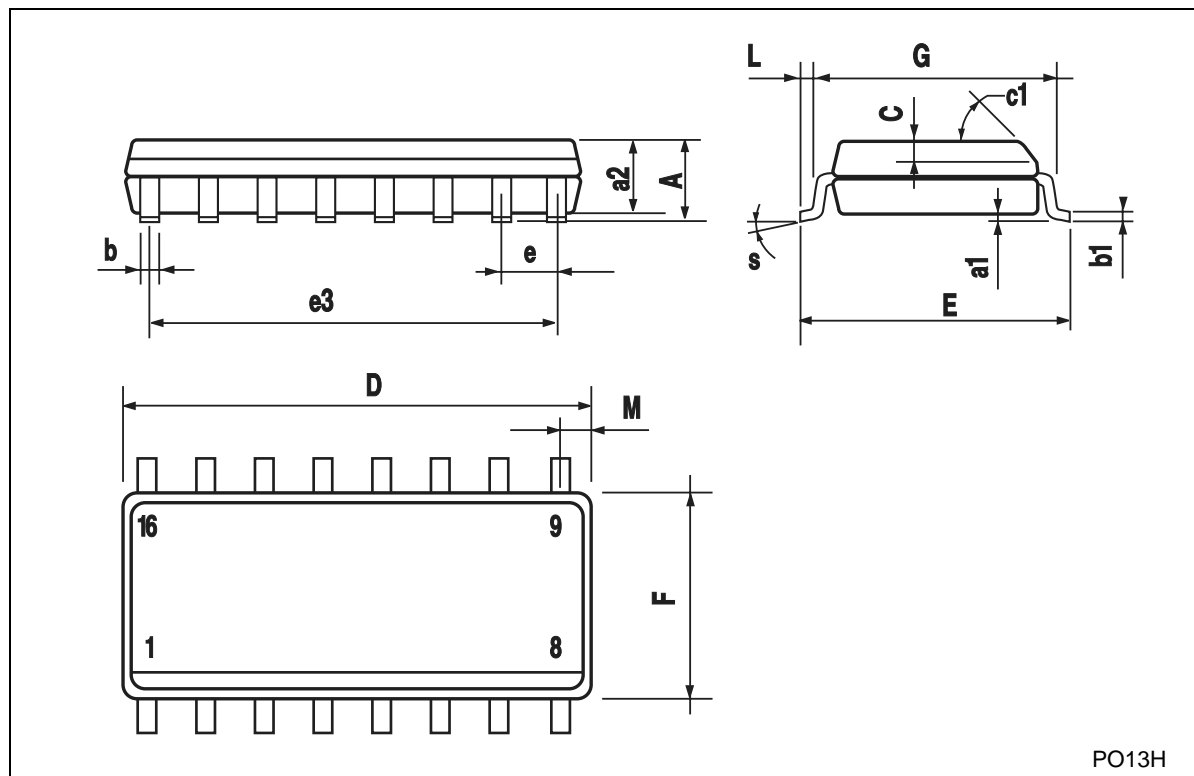

SO-16L MECHANICAL DATA

DIM.	mm.			inch		
	MIN.	TYP	MAX.	MIN.	TYP.	MAX.
A			2.65			0.104
a1	0.1		0.2	0.004		0.008
a2			2.45			0.096
b	0.35		0.49	0.014		0.019
b1	0.23		0.32	0.009		0.012
C		0.5			0.020	
c1	45° (typ.)					
D	10.1		10.5	0.397		0.413
E	10.0		10.65	0.393		0.419
e		1.27			0.050	
e3		8.89			0.350	
F	7.4		7.6	0.291		0.300
G						
L	0.5		1.27	0.020		0.050
M			0.75			0.029
S	8° (max.)					

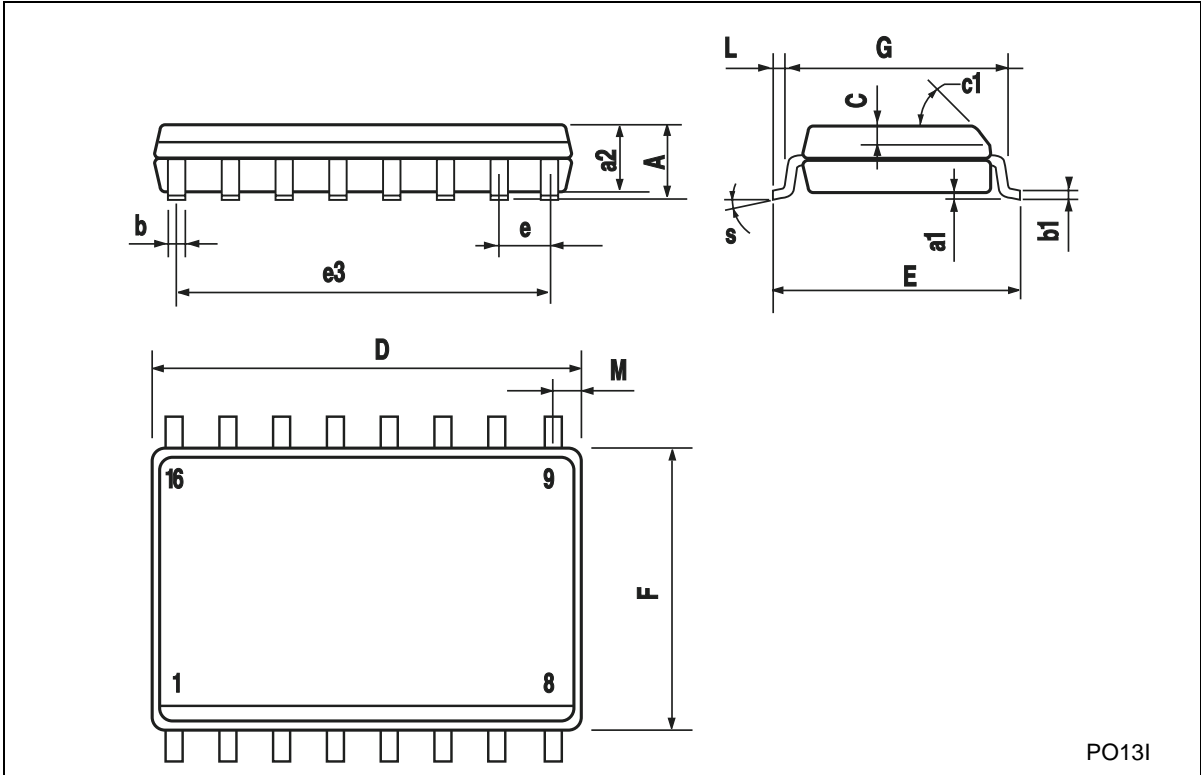

PO13I

TSSOP16 MECHANICAL DATA

DIM.	mm.			inch		
	MIN.	TYP	MAX.	MIN.	TYP.	MAX.
A			1.2			0.047
A1	0.05		0.15	0.002	0.004	0.006
A2	0.8	1	1.05	0.031	0.039	0.041
b	0.19		0.30	0.007		0.012
c	0.09		0.20	0.004		0.0089
D	4.9	5	5.1	0.193	0.197	0.201
E	6.2	6.4	6.6	0.244	0.252	0.260
E1	4.3	4.4	4.48	0.169	0.173	0.176
e		0.65 BSC			0.0256 BSC	
K	0°		8°	0°		8°
L	0.45	0.60	0.75	0.018	0.024	0.030

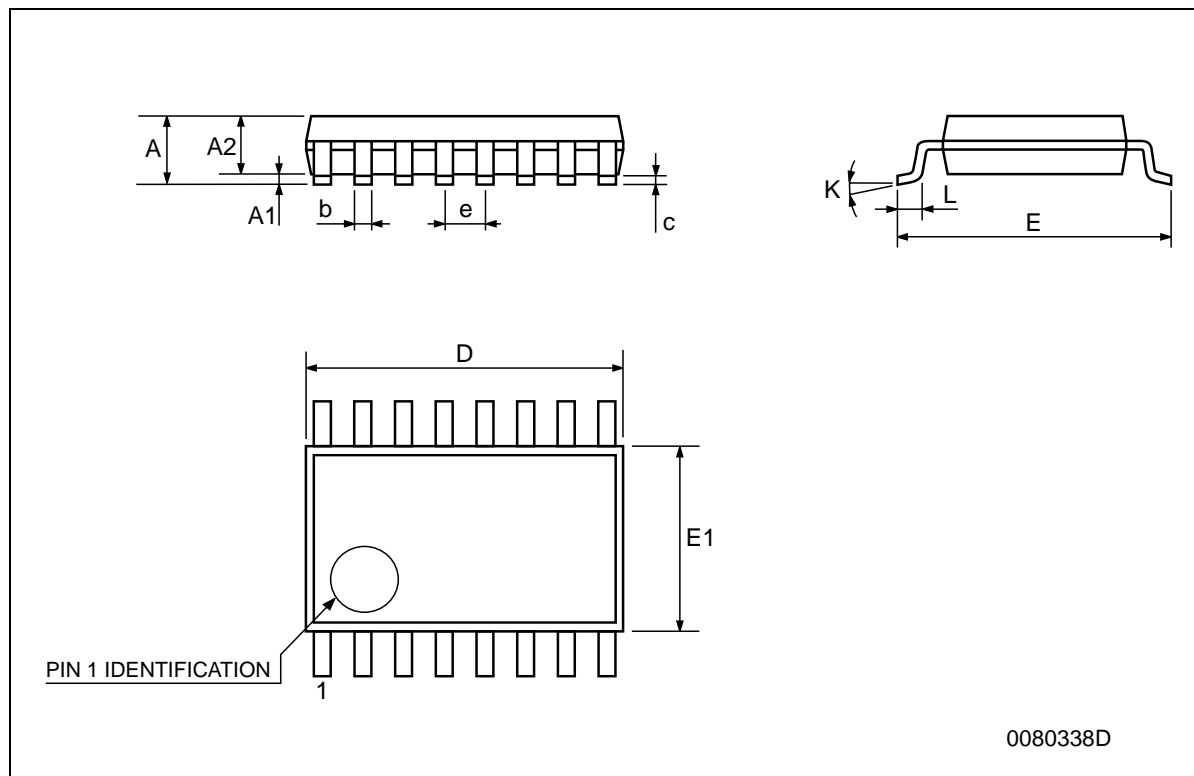

Information furnished is believed to be accurate and reliable. However, STMicroelectronics assumes no responsibility for the consequences of use of such information nor for any infringement of patents or other rights of third parties which may result from its use. No license is granted by implication or otherwise under any patent or patent rights of STMicroelectronics. Specifications mentioned in this publication are subject to change without notice. This publication supersedes and replaces all information previously supplied. STMicroelectronics products are not authorized for use as critical components in life support devices or systems without express written approval of STMicroelectronics.

© The ST logo is a registered trademark of STMicroelectronics

© 2000 STMicroelectronics - Printed in Italy - All Rights Reserved
STMicroelectronics GROUP OF COMPANIES

Australia - Brazil - China - Finland - France - Germany - Hong Kong - India - Italy - Japan - Malaysia - Malta - Morocco
Singapore - Spain - Sweden - Switzerland - United Kingdom

© <http://www.st.com>



This datasheet has been download from:

www.datasheetcatalog.com

Datasheets for electronics components.